

1100 Series 1104C-44TAG2 Diesel Engine – ElectropaK

112.4 kWm @ 1800 rpm

Building upon Perkins proven reputation within the power generation industry, the Perkins® 1100 Series range of ElectropaK engines now fit even closer to the needs of their customers.

With this 1104C-44TAG2 unit, Perkins has engineered for its customers even higher levels of reliability, yet lowered the cost of ownership with six cylinder capability from a four cylinder package performance. Crucially, bare engine noise is lower than ever before.

Rapid starting and pick-up are naturally built-in especially for cold operation, but where legislation or local markets demand an emissions capability, then the 1104C-44TAG2 satisfies EU 2007 Stage II mobile off-highway legislation; and also complies to TA Luft (1986) regulations.

1100 Series see the marriage of technology to customer need. A 4.4 litre unit very quietly setting a new standard in prime power supply and standby for the power generation industry.

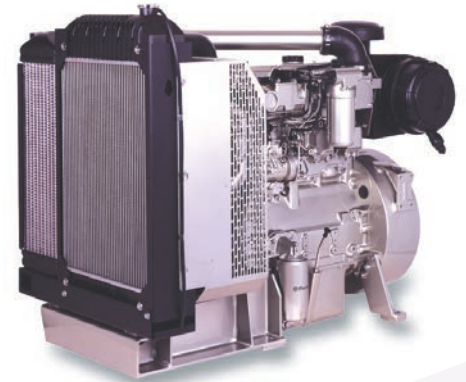

Emissions

Certified against the requirements of EU 2007 (EU 97/68/EC Stage II) legislation for non-road mobile machinery, powered by constant speed engines.

Specification		
Number of cylinders	4 vertical in-line	
Bore and stroke	105 x 127 mm	4.3 x 5.0 in
Displacement	4.41 litres	269 in ³
Aspiration	Turbocharged, air to air charge cooled	
Cycle	4 stroke	
Combustion system	Direct injection	
Compression ratio	18.2:1	
Rotation	Anti-clockwise, viewed on flywheel	
Total lubricating capacity	8.0 litres	2.1 US gal
Cooling system	Water-cooled	
Total coolant capacity	12.6 litres	3.3 US gal

www.perkins.com

Photographs are for illustrative purposes only and may not reflect final specification.
 All information in this document is substantially correct at time of printing and may be altered subsequently.
 Final weight and dimensions will depend on completed specification.

Publication No. PN1714B/12/14 Produced in England ©2014 Perkins Engines Company Limited

Perkins®

THE HEART OF EVERY GREAT MACHINE

1100 Series 1104C-44TAG2 Diesel Engine – ElectropaK

112.4 kWm @ 1800 rpm

Features and benefits

Compact and efficient power

- The Perkins 1100 Series family was developed following an intensive period of customer research. The 3.3 and 4.4 litre engines feature new cylinder blocks which ensure bore roundness is maintained under the pressures of operation, as well as significantly reducing mechanical and combustion noise. A new cross-flow cylinder head design optimises combustion control, and combines with turbocharger and charge cooler technology to achieve the best combination of power delivery and low exhaust emissions

Cleaner and quieter power

- The refined structure of the 1100C range leads to an exceptionally low noise signature. To meet environmental needs swirl conditioned air is delivered through the new cross-flow cylinder head, and burns cleanly with the high pressure fuel from an advanced technology rotary pump

Cost effective power

- The compact packaging and low noise performance of the 1100C range bring clear benefits to the Genset packager. Low cost of operation is assured by lower fuel and oil consumption and 500 hour service intervals
- **Warranties and Service Contracts**
We provide one-year warranties for constant speed engines and two-year warranties for variable speed models, as standard. These are supported by multilevel Extended Service Contracts that can be bought additionally
Discover more: www.perkins.esc

Product support

- Perkins actively pursues product support excellence by ensuring our distribution network invest in their territory – strengthening relationships and providing more value to you, our customer
- Through an experienced global network of distributors and dealers, fully trained engine experts deliver total service support around the clock, 365 days a year. They have a comprehensive suite of web based tools at their fingertips covering technical information, parts identification and ordering systems, all dedicated to maximising the productivity of your engine
- Throughout the entire life of a Perkins engine, we provide access to genuine OE specification parts and service. We give 100% reassurance that you receive the very best in terms of quality for lowest possible cost .. wherever your Perkins powered machine is operating in the world
- To find your local distributor: www.perkins.com/distributor

www.perkins.com

Photographs are for illustrative purposes only and may not reflect final specification.
All information in this document is substantially correct at time of printing and may be altered subsequently.
Final weight and dimensions will depend on completed specification.

Publication No. PN1714B/12/14 Produced in England ©2014 Perkins Engines Company Limited



Perkins[®]

THE HEART OF EVERY GREAT MACHINE

1100 Series 1104C-44TAG2 Diesel Engine – ElectropaK

112.4 kWm @ 1800 rpm

Technical information

Air inlet

- Mounted air filter

Fuel system

- Rotary type pump
- Ecoplus fuel filter

Lubrication system

- Wet cast iron sump with filler and dipstick
- Spin-on oil filter

Cooling system

- Thermostatically-controlled system with gear-driven circulation pump and belt-driven pusher fan
- Mounted radiator and piping incorporating air-to-air charge cooler

Electrical equipment

- 12 volt starter motor and 12 volt 65 amp alternator with DC output
- 12 volt shutdown solenoid energised to run
- Glow plug cold start aid

Flywheel and housing

- Flywheel to SAE J620 size 10/11½
- SAE 3 flywheel housing

Literature

- User's Handbook

Optional equipment

- 24 volt alternator
- 24 volt starter motor
- Workshop manual
- Parts book

www.perkins.com

Photographs are for illustrative purposes only and may not reflect final specification.
All information in this document is substantially correct at time of printing and may be altered subsequently.
Final weight and dimensions will depend on completed specification.

Publication No. PN1714B/12/14 Produced in England ©2014 Perkins Engines Company Limited

 **Perkins®**

THE HEART OF EVERY GREAT MACHINE

1100 Series 1104C-44TAG2 Diesel Engine – ElectropaK

112.4 kWm @ 1800 rpm

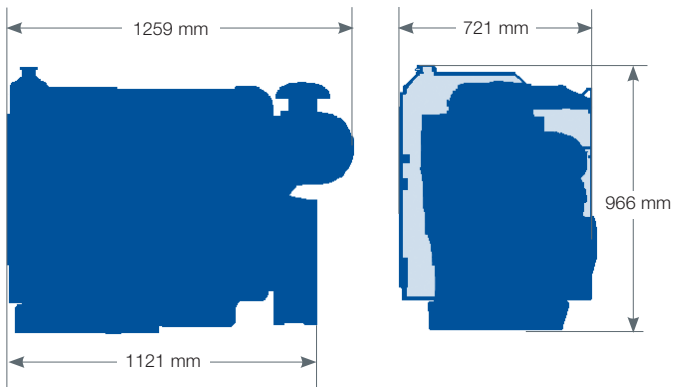

Engine package weights and dimensions		
Length	1259 mm	45.5 in
Width	721 mm	28.3 in
Height	966 mm	38.0 in
Weight (dry)	550 kg	1212 lb

www.perkins.com

Photographs are for illustrative purposes only and may not reflect final specification.
 All information in this document is substantially correct at time of printing and may be altered subsequently.
 Final weight and dimensions will depend on completed specification.

Publication No. PN1714B/12/14 Produced in England ©2014 Perkins Engines Company Limited

Perkins®

THE HEART OF EVERY GREAT MACHINE

1100 Series 1104C-44TAG2 Diesel Engine – ElectropaK

112.4 kWm @ 1800 rpm

Speed rpm	Type of operation	Typical generator output (Net)		Engine power			
				Gross		Net	
		kVA	kWe	kWm	hp	kWm	hp
1800	Prime power	114.4	91.5	106.8	143.2	101.7	136.3
	Standby (maximum)	126.5	101.2	117.5	157.5	112.4	150.7

The above ratings represent the engine performance capabilities to conditions specified in ISO 8528/1, ISO 3046/1:1986, BS 5514/1. Derating may be required for conditions outside these; consult Perkins Engines Company Limited.

Generator powers are typical and are based on typical alternator efficiencies and a power factor and a power factor (cos θ) of 0.8.

Fuel specification: BS 2869 Class 2 or ASTM D975 D2. Lubricating oil: API CH4/ACEA E5.

Rating definitions

Prime power: Power available for variable load in lieu of a main power network. Overload of 10% permitted for 1 hour in every 12 hours operation.

Standby (maximum): Power available at variable load in the event of a main power network failure. No overload is permitted.

Percent of prime power	Fuel consumption at 1800 rpm g/kWh	Fuel consumption at 1800 rpm l/hr
Standby (maximum)	214	29.7
Prime power	218	26.9
75%	218	20.2
50%	228	14.1

www.perkins.com

Photographs are for illustrative purposes only and may not reflect final specification. All information in this document is substantially correct at time of printing and may be altered subsequently. Final weight and dimensions will depend on completed specification.

Publication No. PN1714B/12/14 Produced in England ©2014 Perkins Engines Company Limited



Perkins®

THE HEART OF EVERY GREAT MACHINE